

## SecurePlus Flip Lid

Security at the point of sale is becoming increasingly vital to all retailers. Cash Bases have recognised this need and developed the SecurePlus portfolio, which ensures that both checkout staff and cash are protected.

### DESCRIPTION

A robust, durable, compact cash drawer that has been designed to withstand excessive forced entry.

### FEATURES

- Robust steel construction
- Drawer status micro switch
- Heavy duty latching mechanism
- Steel face plate
- Radial pin tumbler lock
- Bolt down facility in base

### OPTIONS

- Wide range of plastic or steel inserts
- Floppy note dividers to maximize note storage
- Fixed or removable coin cups
- Coin cups suitable for weigh counting
- Anti grab flap over the note compartment
- Media posting slot
- Lockable lid for the insert
- No lock
- Base plate for secure fixing + quick release
- Stainless steel finish for the lid

### SPECIFICATION

#### FL-460

- Width: 460mm
- Depth: 175mm
- Height: 100mm
- Weight moulded insert: 5kg
- Weight universal insert: 7kg

#### FL-490

- Width: 490mm
- Depth: 175mm
- Height: 110mm

### IDEAL FOR

- Supermarkets
- Hypermarkets
- Petrol Forecourts

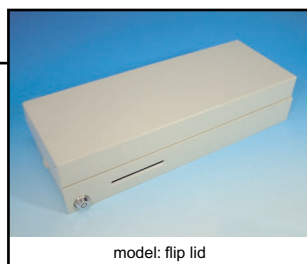
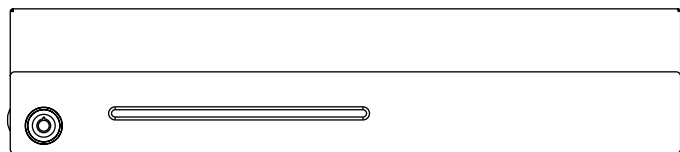
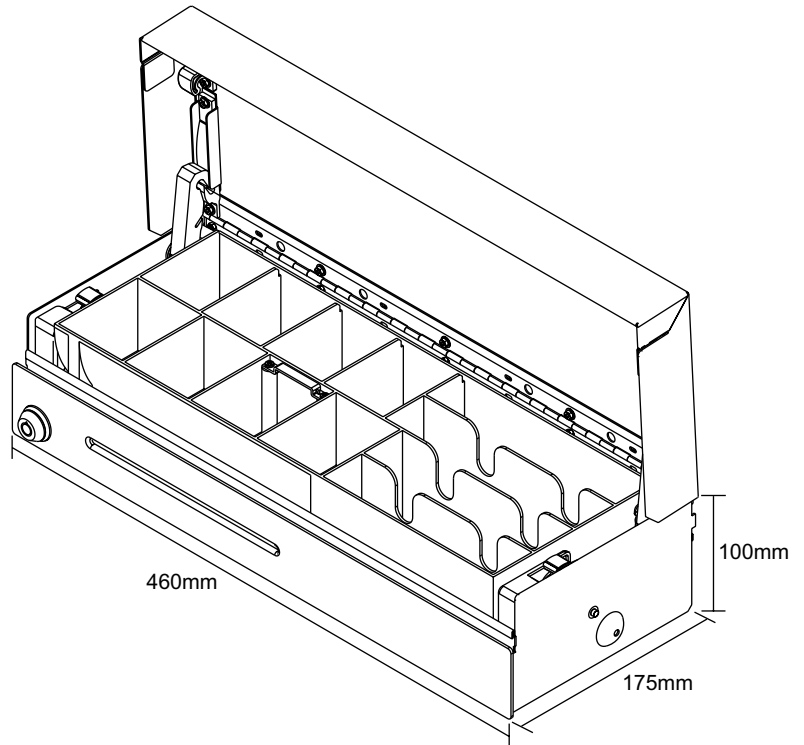

model: flip lid



option: universal insert



feature: radial tumbler lock

UK/SP-FLIPLID/0603



Specification may be subject to change without notification

## SECUREPLUS

CASH BASES LTD ■ NEWHAVEN, EAST SUSSEX BN9 0LA ■ UK ■ [www.cashbases.net](http://www.cashbases.net)  
 TEL: +44 [0] 1273 616300 ■ FAX: +44 [0] 1273 512010 ■ EMAIL: [sales@cashbases.co.uk](mailto:sales@cashbases.co.uk)